



东莞市东颂电子有限公司
DONGGUAN DONGSONG ELECTRONIC CO.,LTD

SPECIFICATION FOR APPROVAL

CUSTOMER : 01161 REV.00
ARTICLE: AC-DC ADAPTER
STANDARD : BS
MODEL NO. : DYS062-075100W-5
OUR PART NO.: DYS062-075100W-15A13A
INPUT : 100-240V AC 50/60Hz
OUTPUT: 7.5V DC 1.0A

供应商确认			客户确认		
Made by	Checked by	Approved by	Made by	Checked by	Approved by
黄建兰	刘飞	宾成			

DONGGUAN DONGSONG ELECTRONIC CO., LTD

Add: Dongsong Electronic Building, No.19, Xintian Street, Baizhoubian Village,
East District, Dongguan City, Guangdong Province, China.

TEL: (86)0769-88787891

FAX: (86)0769-88703948

E-mail: dys3948@163.com

[Http://www.dys-cn.com](http://www.dys-cn.com)

DONGGUAN DONGSONG ELECTRONIC CO.,LTD
SWITCHING MODE POWER SUPPLY
SPECIFICATION

Model No.:DYS062-075100W-5

REV.00

Date: 2015/10/13

CONTENTS

1. Record of Revision:	3
2. Descriptions:	4
3. Input Feature:	4
4. Output Feature:	4-5
5. Protection Feature:	5
6. Safety Standards:	6
7. Reliability:	6
8. Mechanical Specifications:	6
9. Environmental Conditions:	7
10. Main Measurement Equipments:	7
11. Case Drawing:	8
12. DC Cable Drawing:	9
13 Lable Drawing:	10
14. Package Drawing:	11

DONGGUAN DONGSONG ELECTRONIC CO.,LTD
SWITCHING MODE POWER SUPPLY
SPECIFICATION

Model No.:DYS062-075100W-5

REV.00

Date: 2015/10/13

1. Record of Revision:

REVISION	DESCRIPTIONS OF CHANGE	DATE	ACTOR
REV.00	New document	2015/10/13	黄建兰

Made by: 黄建兰

Checked by: 刘飞

Approved by: 宾成^{3 of 11}

DONGGUAN DONGSONG ELECTRONIC CO.,LTD
SWITCHING MODE POWER SUPPLY
SPECIFICATION

Model No.:DYS062-075100W-5

REV.00

Date: 2015/10/13

2. Descriptions:

These are a series of general purpose AC/DC adapters which convert 100Vac ~ 240Vac to a stabilized DC voltage of 7.5V with rated output current of 1000mA. Please connect the electrical power first and then add the load when using this SMPS.

The switching mode power supply meets the requirements of lead free and ROHS.

3. Input Feature:

3.1 Input Voltage and Frequency

The switching mode power supply shall meet all specifications when powered from the following sources.

Rating Voltage	Line Frequency	Minimum Voltage	Maximum Voltage
100-240V AC	50/60Hz	90V AC	264V AC

3.2 Efficiency

The minimum efficiency shall be 74.89% under 115Vac/230Vac input and output full load.

3.3 Input Current

The maximum input current shall be less than 0.2A.

3.4 Input In-rush Current

Peak inrush current shall be limited to 50A.

3.5 Input Leakage Current

The leakage current shall not exceed 0.25mA.

4. Output Feature:

4.1 Output Voltage and Current

The switching mode power supply shall have one regulated DC output voltage: 7.5V DC.

The table below defines the total regulation banding for the output, which includes line regulation, load regulation, transient response, and effects due to environmental conditions and aging.

Voltage shall be measured at its output connector.

DONGGUAN DONGSONG ELECTRONIC CO.,LTD
SWITCHING MODE POWER SUPPLY
SPECIFICATION

Model No.:DYS062-075100W-5

REV.00

Date: 2015/10/13

Output	Output Current Range		Output Voltage Range		Ripple & Noise
	Min	Max	Min	Max	Max.
+7.5V	0.0A	1.5A	7.125V	7.875V	300mVpp

Ripple & Noise Test: Add 0.1uF/50V ceramic capacitor and 10uF/50V aluminum electrolytic capacitor across the output terminal. Measured with 20MHz Bandwidth Oscilloscope.

4.2 Dynamic Response

The load current of the output is changed between 25% and 75% under full load at 0.5A/ms; the excursion of the output shall not exceed 10% of the nominal output voltage. The output voltage shall be within 10% of the steady state voltage in 1ms.

4.3 Startup and Turn- on Delay

The switching mode power supply shall be able to start up into a resistive load up to the maximum rated current with maximum load capacitance of 1,000uF. The elapsed time between the application of input power and the attainment of output voltage to the nominal value shall not exceed 3 seconds.

5. Protection Feature:

5.1 Over Current Protection

The switching mode power supply shall withstand a continuous over current without damage. It may be applied before power-up, or after power-up. The switching mode power supply shall perform normally again after the over current is removed.

5.2 Short Circuit Protection

Short circuit will not cause the switching mode power supply to damage, or any safety hazards. It shall perform normally again after the short circuit is removed.

DONGGUAN DONGSONG ELECTRONIC CO.,LTD
SWITCHING MODE POWER SUPPLY
SPECIFICATION

Model No.:DYS062-075100W-5

REV.00

Date: 2015/10/13

6. Safety Standards:

6.1 Safety

The switching mode power supply has approved by the following safety standards:

*EN 60950

6.2 Dielectric Strength (HI-POT)

Input to Output Terminal: 4242Vdc 3Sec \leq 5mA.

Input to Case: 4242Vdc 3Sec \leq 5mA.

When DC voltage of 4.24KV is applied, and the voltage applied to the insulation under test, it gradually rises from zero to the prescribed voltage in 1s, and holds at the value for 3s between the input and output, and between the input and housing, the current sensitivity shall be less than 5mA, after the test, the switching mode power supply shall exhibit no electrical and mechanical abnormalities.

7. Reliability:

7.1 Burn-in

The burn-in test will be performed at least 3 hours at 25 degrees centigrade under full load.

7.2 MTBF

When the operation is complying with this specification, the MTBF of switching mode power supply will be 25K hours at 25 °C.

8. Mechanical Specifications:

Weight:	About 58g
Dimensions:	Refer Outline on page 8
Input socket:	BS PLUG.
Output cord:	DCD1449,24AWG UL2468,1.5M Black
Output Connector:	Lead O/P~OD: 4.0mm, ID: 1.7mm, Length: 9.5mm (H).

DONGGUAN DONGSONG ELECTRONIC CO.,LTD
SWITCHING MODE POWER SUPPLY
SPECIFICATION

Model No.:DYS062-075100W-5

REV.00

Date: 2015/10/13

9. Environmental Conditions:

The switching mode power supply shall meet all requirements of this specification on any combination of operation ambient conditions and after exposure to any combination of non-operation ambient conditions specified in this section.

9.1 Temperature

Operating Temperature: 0°C~40°C

Storage Temperature: -20°C~60°C

9.2 Humidity

Operating Humidity: 10%~90%(non condensing)

Relative Humidity: 5%~95% non condensing

10. Main Measurement Equipments:

- A. AC Source: YOKOGAWA JL-1005A-500W
- B. Power Meter: Everfine YF9901
- C. Electronic Load: Yokogawa IT8511
- D. Oscilloscope: Matrix Mos-620CH 20MHZ
- E. Digital Multimeter: Victor Vc890D
- F. DC Power: RS1305DN
- .G. HI-POT Tester: CHANGSHENG CS2670
- H. Insulation Resistance Tester: TRANST TR7122

DONGGUAN DONGSONG ELECTRONIC CO.,LTD

SWITCHING MODE POWER SUPPLY

SPECIFICATION

Model No.:DYS062-075100W-5

REV.00

Date: 2015/10/13

11. Case Drawing:

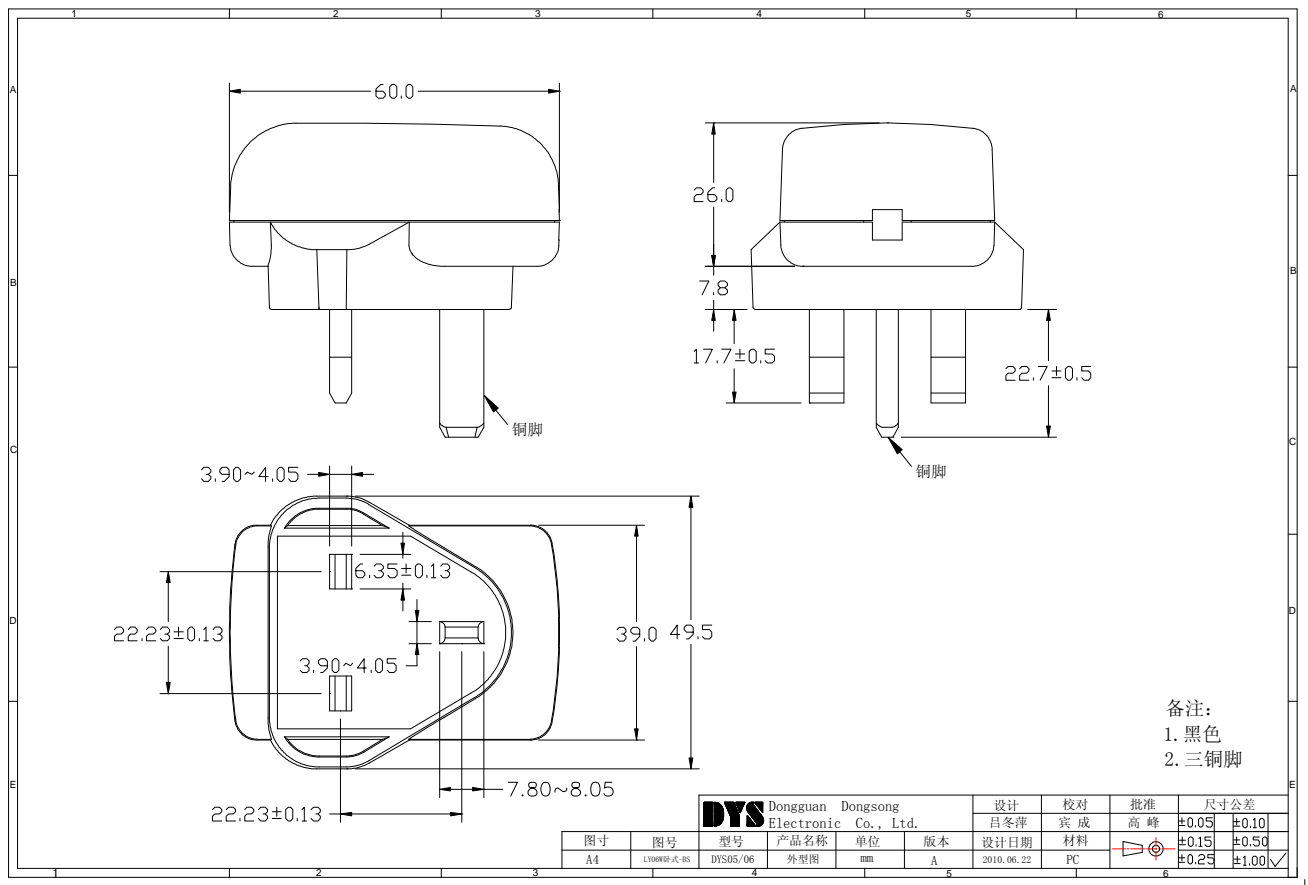

Made by: 黄建兰

Checked by: 刘飞

Approved by: 宾成 ^{8 of 11}

DONGGUAN DONGSONG ELECTRONIC CO.,LTD

SWITCHING MODE POWER SUPPLY

SPECIFICATION

Model No.:DYS062-075100W-5

REV.00

Date: 2015/10/13

12. DC Cable Drawing:

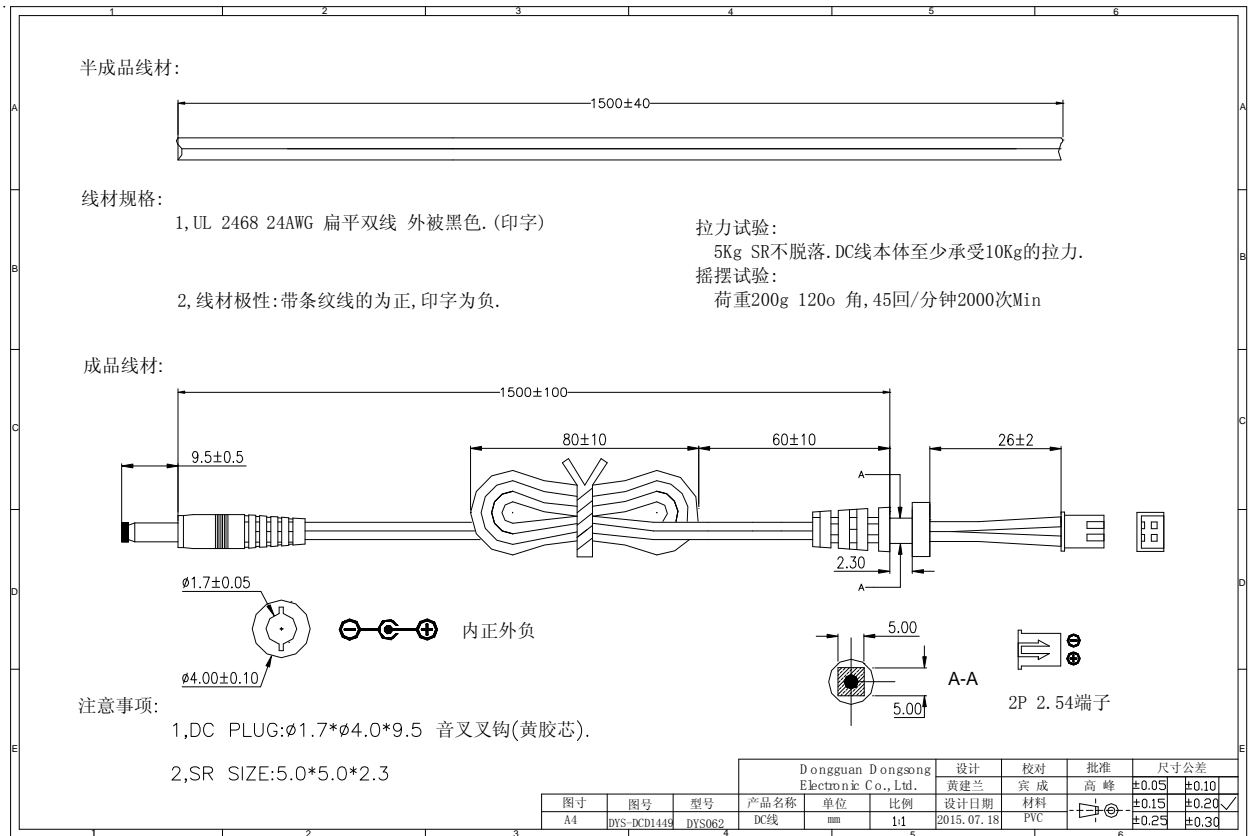

Made by: 黄建兰

Checked by: 刘飞

Approved by: 宾成^{9 of 11}

DONGGUAN DONGSONG ELECTRONIC CO.,LTD

SWITCHING MODE POWER SUPPLY

SPECIFICATION

Model No.:DYS062-075100W-5

REV.00

Date: 2015/10/13

13. Lable Drawing:

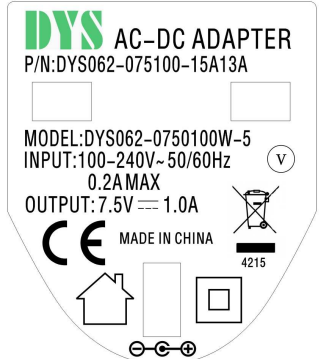
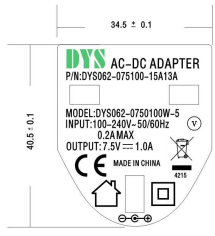
1	2	3	4	5	6
A					A
B					B
C	<p>此图为1:1之图型模板</p>				C
D	<p>★ 4215其中42代表多少周，15代表年份，此日期需随着生产周期的变动而变动，如有特殊请以业务通知为准</p>				D
E	<p>注：DYS图标为绿色 版面为银底黑字 材质为消银龙 耐温85℃ 厚度为0.25 ± 0.01 符合无铅标准</p>				E
1	2	3	4	5	6

DYS Dongguan Dongsong Electronic Co., Ltd.	
名称: 铭牌	REV: A
图号: DYS062-LB15A13A	型号: DYS062-075100W-5
尺寸公差	比例: 1:1
±0.05	±0.10
±0.15	±0.20
单位	绘图
日期	日期
黄建兰	黄建兰
校对	批准
宾成	高峰

DONGGUAN DONGSONG ELECTRONIC CO.,LTD

SWITCHING MODE POWER SUPPLY

SPECIFICATION

Model No.:DYS062-075100W-5

REV.00

Date: 2015/10/13

14. Package Drawing:

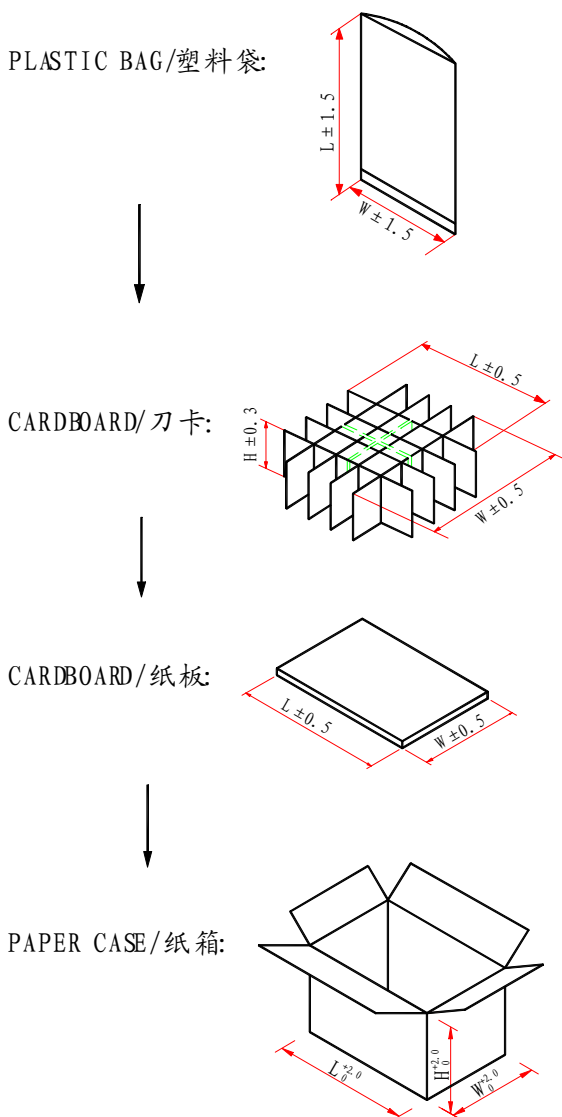

MECHANICAL DIMENSION:

	L(mm)	W(mm)	H(mm)
PLASTIC BAG	160	130	
CARDBOARD	335	48	
CARDBOARD	460	48	
CARDBOARD	460	335	
PAPER CASE	470	345	230

PACKING METHOD:

PACKING METHOD	20PCS/LAYER * 4 LAYERS
QTY	80PCS
N.G	8.0Kg
G.W	8.5Kg

Made by: 黄建兰

Checked by: 刘飞

Approved by: 宾成^{11 of 11}